

2000 TJ – 2005 Hemi5.7L MDS Engine

TJ under dash connectors:

| | |
|------|--------|
| C202 | Gray |
| C203 | Green |
| C204 | Red |
| C108 | Blue |
| C107 | Yellow |
| C106 | Black |
| C322 | Black |
| C323 | Red |

PCM programming:

Program SKREEM
Program Keys
Program VIN

Turn off ABS and Traction Control
Turn off ATC (use MTC)
Turn off Airbag
Turn off radio
Turn off overhead console
Turn off window controls
Turn off Tire Pressure sensors

Air Conditioning

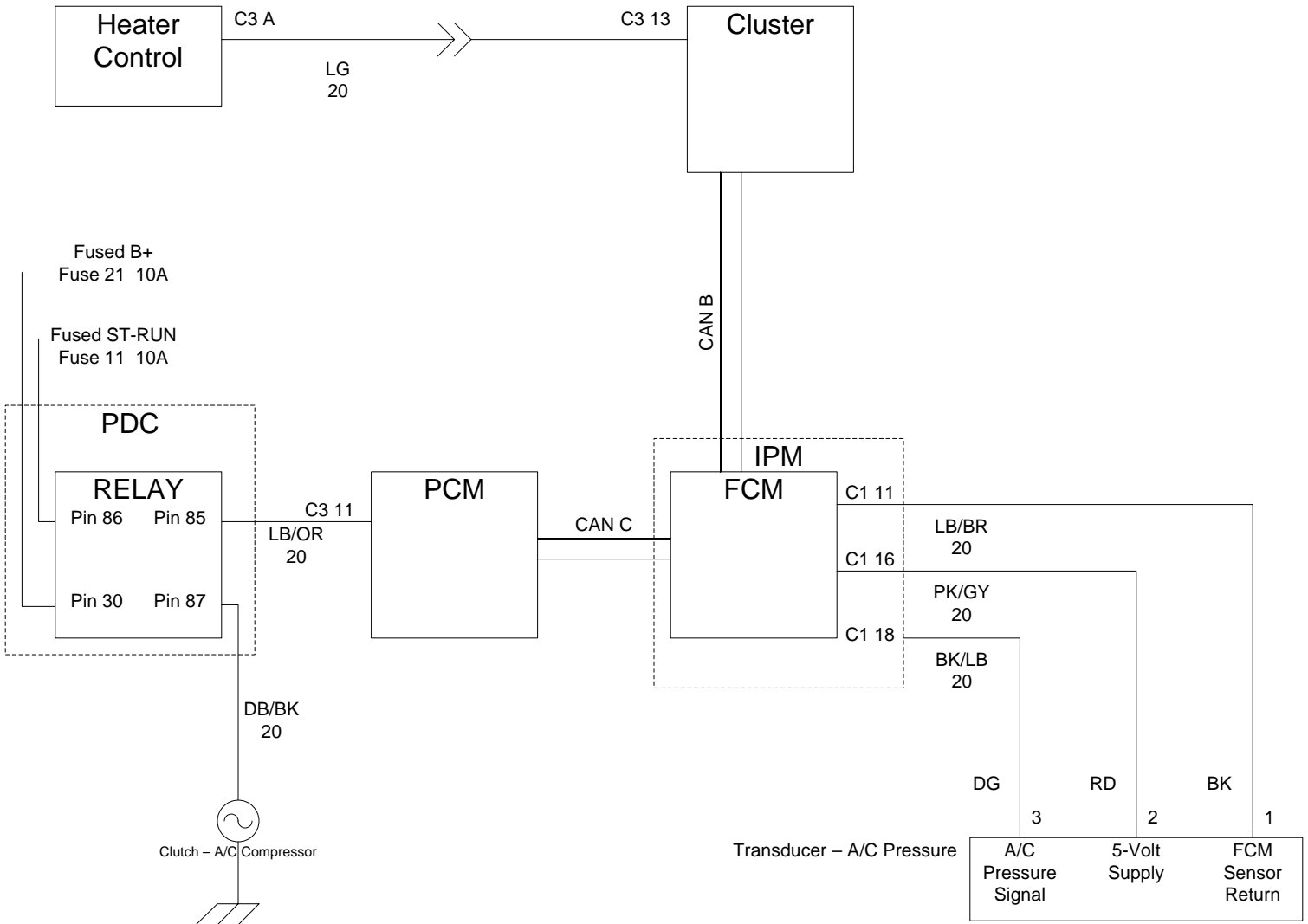

Pressure Transducer:
 allows AC between 16 and 447PSI
 >240 PSI avtivates cooling fan
 < 40 degrees F deactivates A/C

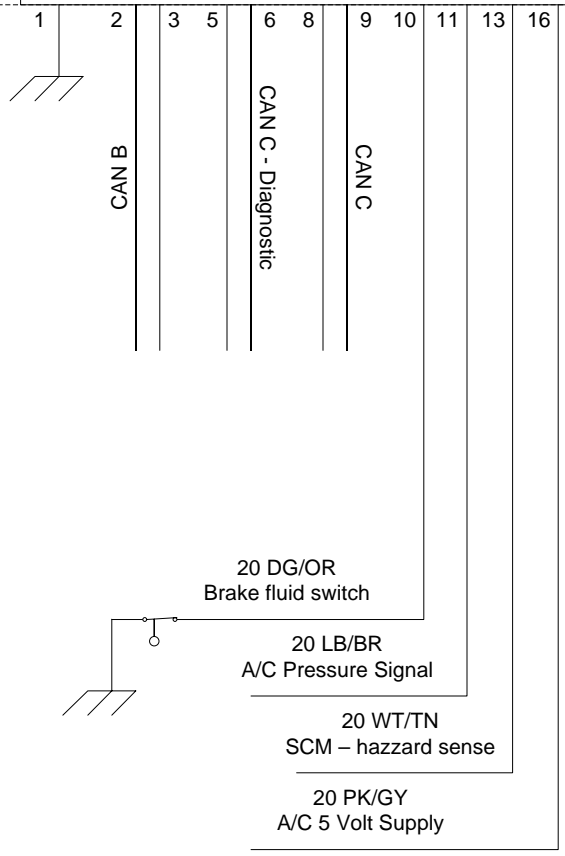
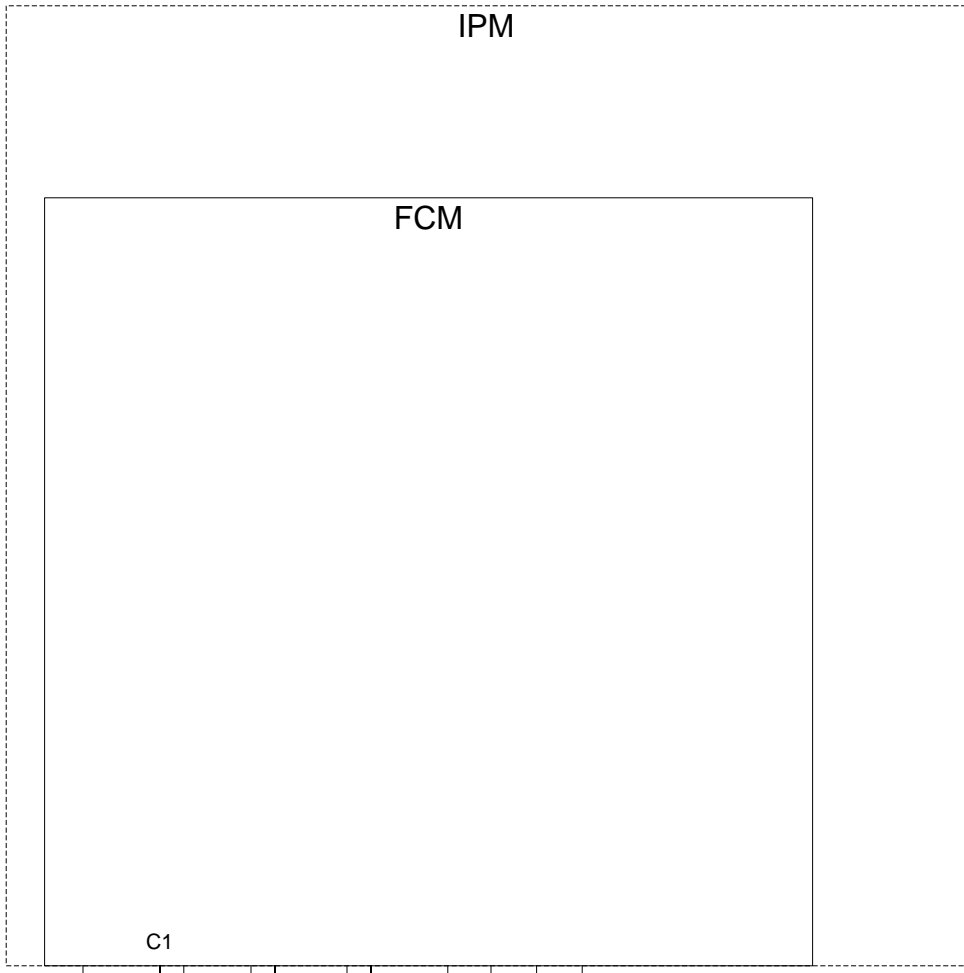

C1 11

C1 16

C2

Rear Lighting

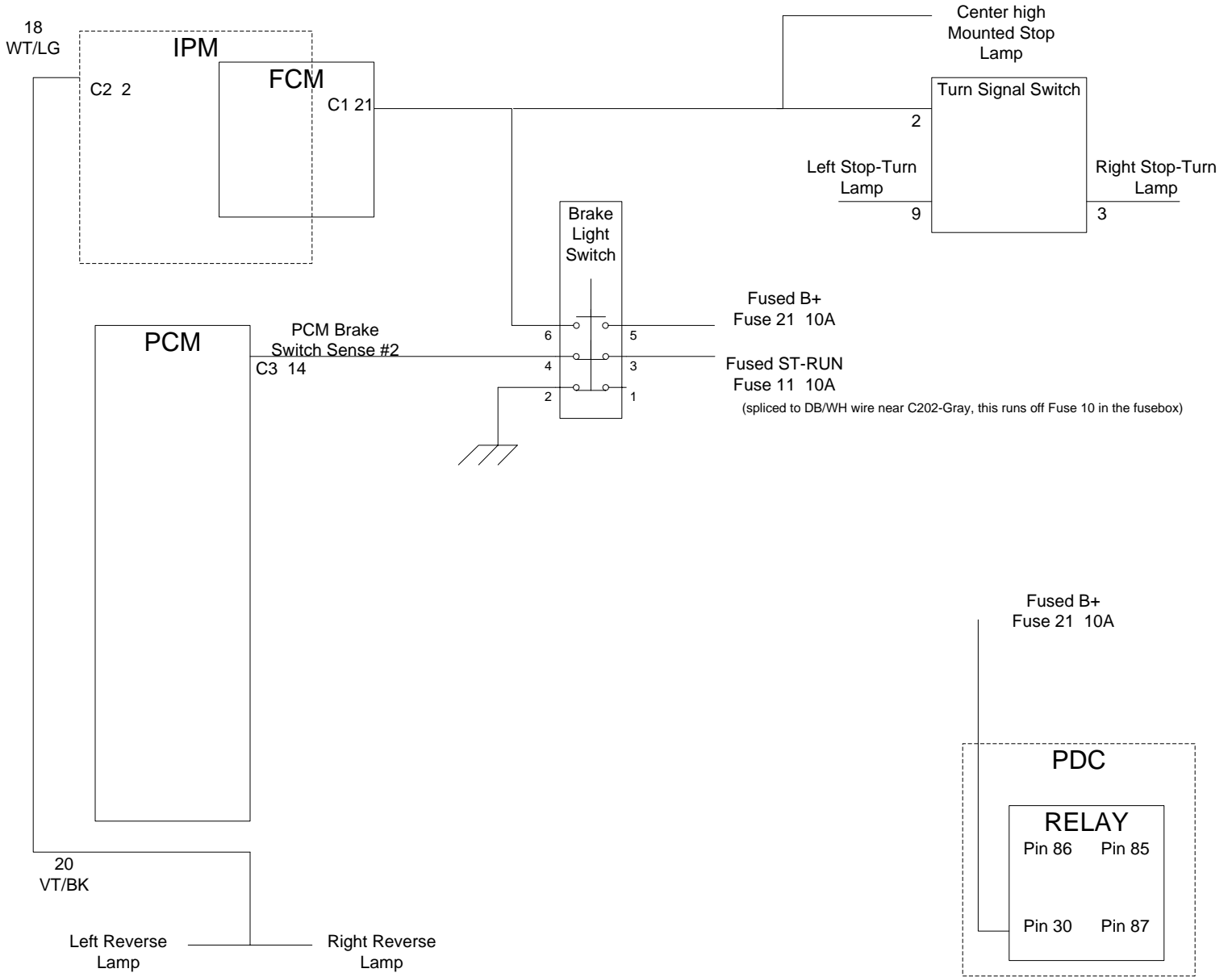

Module – Sentry Key Remote Entry

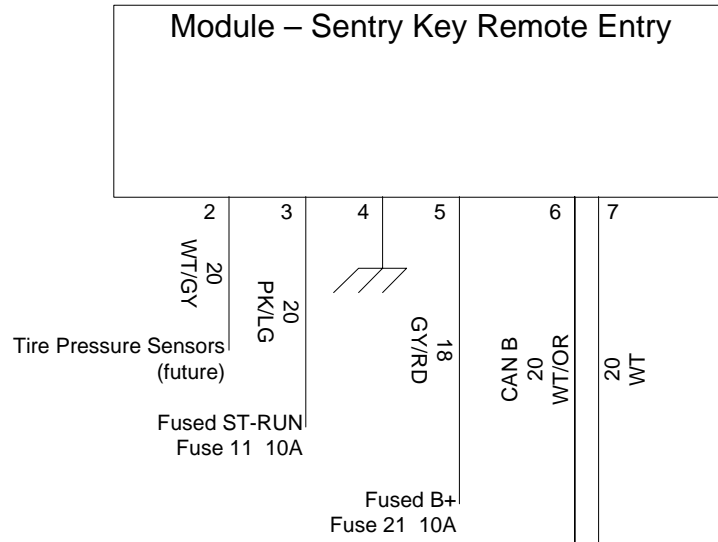

Starting System

